

GT-TC165X-HXXX-LX

G-SWITCH

Operating Force
 A=60gf
 B=70gf
 C=80gf

Switch Height (mm)
 H0715=7.15mm

Switch lifetime (Force)
 L10=1,000,000 Cycles
 L50=5,000,000 Cycles

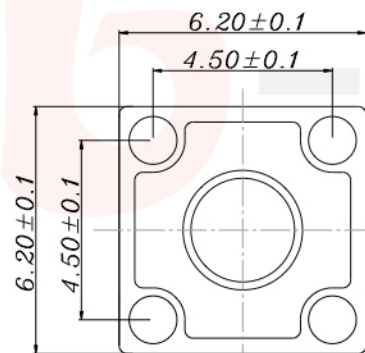

P.C.B LAND DIMENSION

G-Switch Specification:

Operating temperature range : -30°Cto+85°C
 Rating : 50mA.12V DC
 Insulation resistance: : 100MΩ min.100V DC
 Dielectric strength : 250V AC for 1 min
 Contact resistance: : 100m Ω max.
 Travel:0.20±0.1mm

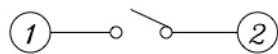

CIRCUIT DIAGRAM



G-Switch Electronic (HongKong) CO.,Ltd.

Unless otherwise specified, Tolerance:
 X. ±0.30
 X.x ±0.20
 X.xx ±0.15
 X.xxx ±0.10
 Angles ±3°

DESIGN FengFengChen DATE 2019.05.29
 CHECKED DATE
 APPROVED DATE
<http://www.dg-switch.com>
 TEL:0769-82388879

Molde code:
GT-TC165X-HXXX-LX
 REV.: X1 SCALE: 4:1 UNIT: mm
 SIZE: A4 SHEET: 1/1