

GT-TC100X-HXXX-LX

G-SWITCH

Operating Force

- A=160gf
- B=250gf
- C=100gf
- D=70gf
- E=130gf
- F=320gf
- G=400gf

Switch lifetime (Force)

- L05=50,000 Cycles
- L1=100,000 Cycles
- L3=300,000 Cycles
- L5=500,000 Cycles

Switch Height (mm)

- H043=4.3(A3.5) H050=5.0(A3.5)
- H055=5.5(A3.5) H060=6.0(A3.5)
- H065=6.5(A3.5) H070=7.0(A3.3)
- H080=8.0(A3.3) H085=8.5(A3.3)
- H090=9.0(A3.3) H095=9.5(A3.0)
- H100=10.0(A3.0) H105=10.5(A3.0)
- H110=11.0(A3.0) H115=11.5(A3.0)
- H120=12.0(A3.0) H125=12.5(A3.0)
- H130=13.0(A3.0) H135=13.5(A3.0)
- H140=14.0(A3.0) H145=14.5(A3.0)
- H150=15.0(A3.0) ...

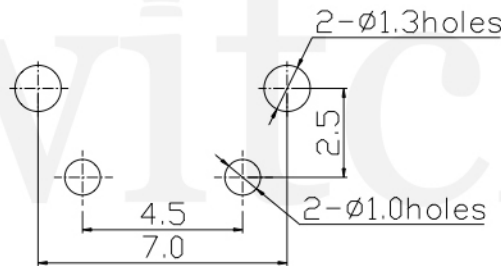
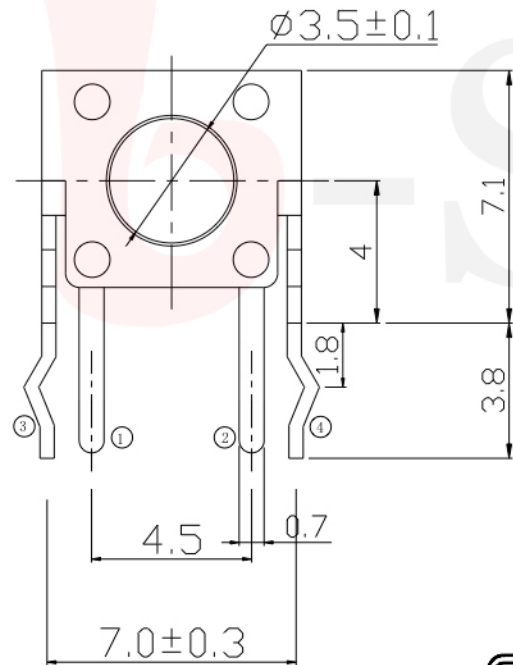

P.C.B LAND DIMENSION

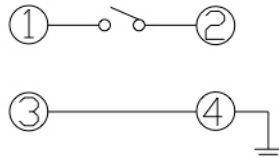

CIRCUIT DIAGRAM

G-Switch Specification:

Operating temperature range : -30°Cto+85°C
 Rating : 50mA.12V DC
 Insulation resistance: : 100MΩ min.100V DC
 Dielectric strength : 250V AC for 1 min
 Contact resistance: : 100m Ω max.
 Travel:0.25±0.1mm



		G-Switch Electronic (HongKong) CO.,Ltd.		
				DESIGN FengFengChen
Unless otherwise specified, Tolerance:		CHECKED	DATE	GT-TC100X-HXXX-LX
X. ±0.30		APPROVED	DATE	
X.x ±0.20		http://www.dg-switch.com		REV.: X1
X.xx ±0.15		TEL:0769-82388879		SCALE: 4:1
X.xxx ±0.10				UNIT: mm
Angles ±3°				SIZE: A4
				SHEET: 1/1