

GT-TC157X-HXXX-LX

G-SWITCH

Operating Force
 A=160gf
 B=250gf
 C=100gf

Switch Height (mm)
 H043=4.3mm
 H050=5.0mm
 H060=6.0mm
 H070=7.0mm

Switch lifetime (Force)
 L1=100,000 Cycles

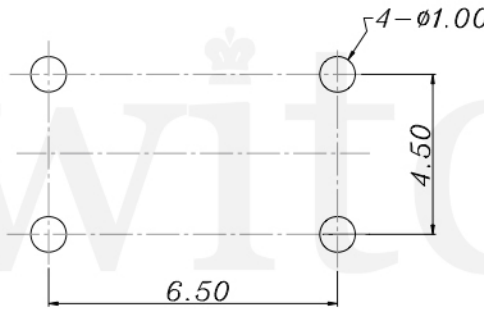
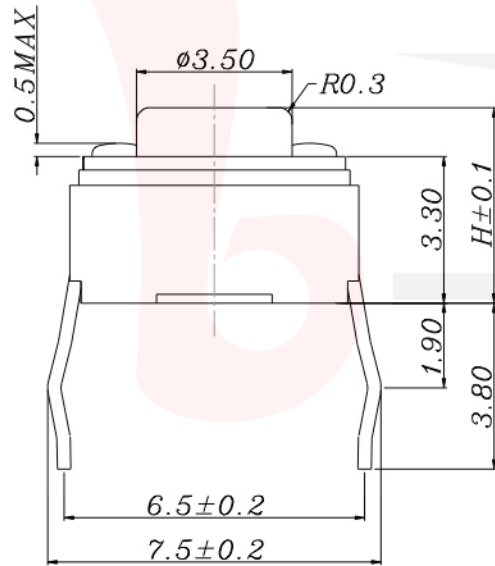

印制线路板

Recommended P.C.B layout

G-Switch Specification:

Operating temperature range : -30°Cto+85°C
 Rating : 50mA.12V DC
 Insulation resistance : 100MΩ min.100V DC
 Dielectric strength : 250V AC for 1 min
 Contact resistance : 100m Ω max.
 Travel:0.30±0.1mm

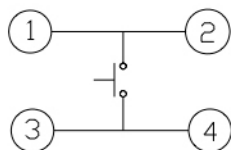

电路简图
 SCHEMATIC



	G-Switch Electronic (HongKong) CO.,Ltd.		
	DESIGN FengFengChen CHECKED APPROVED http://www.dg-switch.com TEL:0769-82388879	DATE 2019.05.29 DATE DATE	Molde code: GT-TC157X-HXXX-LX REV.: X1 SCALE: 4:1 UNIT: mm SIZE: A4 SHEET: 1/1
Unless otherwise specified, Tolerance: X. ±0.30 X.x ±0.20 X.xx ±0.15 X.xxx ±0.10 Angles ±3°			