

截面 1-1

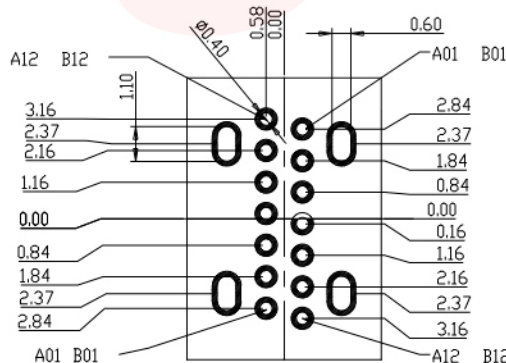

订货编码	H1 ±0.15	H2 ±0.15	H3 ±0.15
7035A	9.30mm	10.8mm	10.9mm
7035B	10.0mm	11.5mm	11.6mm
7035C	10.5mm	12.0mm	12.1mm

SPECIFICATIONS:

- ELECTRICAL CHARACTERISTICS:
 - CONTACT RESISTANCE: 30mΩ MAX.
 - DIELECTRIC WITHSTANDING VOLTAGE: 100V AC FOR ONE MINUTE.
 - INSULATION RESISTANCE: 100MΩ MIN. MEASURED BY 500 VDC
- MECHANICAL CHARACTERISTICS:
 - INSERTION FORCE :0.5-2.0KgF(REF.)
 - WITHDRAWAL FORCE :0.8-2.0KgF(REF.)
- LIFE TEST: 10,000 CYCLES.
- TO CONFORM TO THE KRCONN HAZARDOUS SUBSTANCE FREE SPEC.

RECOMMENDED P.C.B. LAYOUT (T:1.00mm)
TOLERANCE UNSPECIFIED ±0.05mm



b-Switch 品赞科技®

G-Switch Electronic (HongKong) CO.,Ltd

Unless otherwise specified, Tolerance: X. ±0.30 X.x ±0.20 X.xx ±0.15 X.xxx ±0.10 Angles ±3°	DESIGN 陈锋枫 CHECKED APPROVED	DATE 2019.05.29 DATE DATE	TITLE: GT-USB-7035X
http://www.dg-switch.com TEL:0769-82388879	REV.: X1 SCALE: 4:1 SIZE: A4	UNIT: mm SHEET: 1/1	